

ARGANO CON FRENO MANUALE PER TRAZIONE

MANUAL WINCH WITH BRAKE FOR TRACTION

CODICE : 950.270.01P

Rapporto riduzione 1:9.6  
Trazione 9300N (950 Kg)

Riduction ratio 1:9.6  
Traction 9300N (950 Kg)

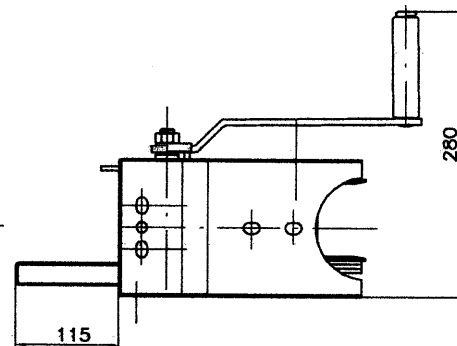
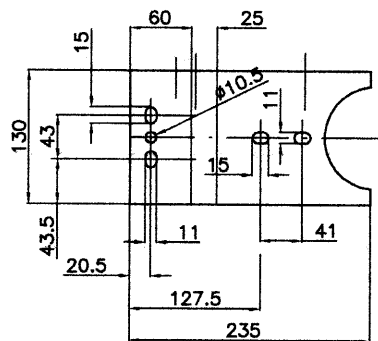

Forza max applicabile 196.2N (20Kg)  
Max force on lever 196.2N (20Kg)

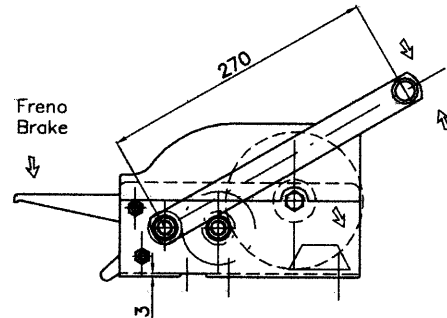
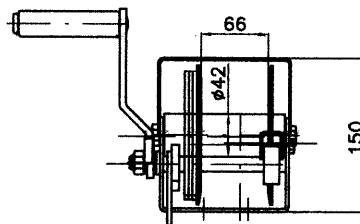

Forza max applicabile  
98.1N (10Kg)  
Max force on lever  
98.1N (10Kg)

Forza max applicabile  
196.2N (20Kg)  
Max force on lever  
196.2N (20Kg)

Traction 9300 N  
(950 Kg)

Traction 9300 N  
(950 Kg)

